

Mixed Ion-Electron Conductivity and Superconductivity in Ceramic Electrolytes

Sebastiano Tosto

Retired Physicist. E-mail: stosto44@gmail.com

The paper concerns a theoretical model on the transport mechanisms occurring when the charge carriers generated during the working conditions of a fuel cell interact with point and line defects in a real lattice of solid oxide electrolyte. The results of a model previously published on this topic are here extended to include the tunnelling of carriers within the stretched zone of edge dislocations. It is shown that at temperatures appropriately low the charge transport turns into a frictionless and diffusionless mechanism, which prospects the chance of solid oxide fuel cells working via a superconductive effect.

1 Introduction

The electric conductivity of ceramic electrolytes for solid oxide fuel cells (SOFC) has crucial importance for the science and technology of the next generation of electric power sources. Most of the recent literature on solid oxide electrolytes concerns the effort to increase the ion conductivity at temperatures as low as possible to reduce the costs and enhance the portability of the power cell. The efficiency of the ion and electron transport play a key role in this respect.

In general different charge transfer mechanisms are active during the working conditions of a fuel cell, depending on the kind of microstructure and temperature of the electrolyte. The ion migration in the electrolyte is consequence of the chemical reactions at the electrodes, whose global free energy change governs the charge flow inside the electrolyte and the related electron flow in the external circuit of the cell. Aliovalent and homovalent chemical doping of the oxides affects the enthalpy of defect formation, whose kind and amount in turn control the diffusivity of the charge carriers and thus their conductivity. Particularly interesting are for instance multi-ion [1] and super-ion [2] conduction mechanisms.

Yet in solid oxide electrolytes several reasons allow also the electronic conduction; are important in this respect the non-stoichiometric structures originated by appropriate heat treatments and chemical doping. In general an oxygen vacancy acts as a charge donor, because the two electrons related to O^{2-} can be excited and transferred throughout the lattice. Oxygen deficient oxides have better conductivity than stoichiometric oxides. Typical case is that of oxygen deficient oxides doped with lower valence cations, e.g. ZrO_2 with Y or Ca . As a possible alternative, even oxide doping with higher valence cations enables an increased amount of electrons while reducing the concentration of oxygen vacancies. Besides, an oxide in equilibrium with an atmosphere of gas containing hydrogen, e.g. H_2O , can dissolve neutral H or hydride H^- or proton H^+ ; consequently the reaction of hydrogen and hydrogen ions dissolved in the oxide with oxygen ions releases electrons to the lattice in addition to the proton conduction.

Mixed ionic–electronic conductors (MIECs) concern in

general both ion, σ_i , and hole/electron, σ_{el} , conductivities of the charge carriers. Usually the acronym indicates materials in which σ_i and σ_{el} do not differ by more than 2 orders of magnitude [3] or are not too low (e.g. $\sigma_i, \sigma_{el} \geq 10^{-5} \text{ S cm}^{-1}$). According to I. Riess [4], this definition can be extended to intend that MIEC is a material that conducts both ionic and electronic charges. A review of the main conduction mechanisms of interest for the SOFC science is reported in [5]. Anyway, regardless of the specific transport mechanism actually active in the electrolyte, during the work conditions of the cell the concentration profiles of the charges generated by the chemical reactions at the electrodes look like that qualitatively sketched in the figure 1.

It is intuitive that the concentration of each species is maximal at the electrode where it is generated. The con-

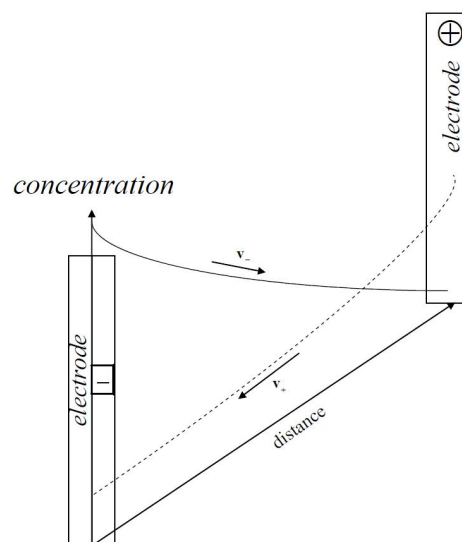

Fig. 1: Qualitative sketch of the concentration profiles of two carriers with opposite charges in the electrolyte as a function of their distance from the electrode where either of them was generated. The profiles represent average diffusion paths, regardless of the local microscopic lattice jumps around the average paths.

centration gradients are sustained by the free energy change of the global reaction in progress; so the charges are subjected to a diffusive driving force \mathbf{F}_c and electric potential gradient driving force \mathbf{F}_ϕ , the latter being related to the non-uniform distribution of charges at the electrodes. In general both forces control the dynamics of all charge carriers.

This picture is however too naive to be realistic. Dopant induced and native defects in the lattice of the electrolyte can interact together and merge to form more complex defects, in particular when the former and the latter have opposite charges, until an equilibrium concentration ratio of single to complex defects is attained in the lattice. Moreover, in addition to the vacancies and clusters of vacancies, at least two further crystal features are to be taken into account in a real material: the line defects and the grain boundaries, which act as potential barriers to be overcome in order that the ions perform their path between the electrodes. The former include edge and screw dislocations that perturb the motion of the charge carriers because of their stress field; the latter have a very complex local configuration because of the pile up of dislocations, which can result in a tangled dislocation structure that can even trap the incoming ions and polygonized dislocation structure via appropriate annealing heat treatments. For instance hydrogen trapping in tangled dislocations is reported in [6]. Modelling these effects is a hard task; exists in the literature a huge amount of microscopic [7] and macroscopic [8] models attempting to describe the transport mechanisms of the charge carriers through the electrolyte.

The former kind of models implements often quantum approaches to get detailed information on a short range scale of phenomena; their main problem is the difficulty of theoretical approach that often requires drastic approximations, with results hardly extrapolable to the macroscopic behaviour of a massive body and scarcely generalizable because of assumptions often too specific.

The latter kind of models regards the electrolyte as a continuous medium whose properties are described by statistical parameters like temperature, diffusion coefficient, electrical conductivity and so on, which average and summarize a great variety of microscopic phenomena; they typically have thermodynamic character that concerns by definition a whole body of material, and just for this reason are more easily generalized to various kinds of electrolytes and transport mechanisms.

A paper has been published to model realistically the electrical conductivity in ceramic lattices used as electrolytes for SOFCs [9]; the essential feature of the model was to introduce the interaction between charge carriers and lattice defects, in particular as concerns the presence of dislocations. It is known that the diffusion coefficient D of ions moving in a diffusion medium is affected not only by the intrinsic lattice properties, e.g. crystal spacing and orientation, presence of impurities and so on, but also by the interaction with point and line defects. The vacancies increase the lattice jump rate

and decrease the related activation energy, thus enhancing the diffusion coefficient; this effect is modelled by increasing purposely the value of D , as the mechanism of displacement of the charge carriers by lattice jumps is simply enhanced but remains roughly the same. More complex is instead the interaction with the dislocation; thinking for simplicity one edge dislocation, for instance, the local lattice distortion due to stress field of the extra-plane affects the path of the ions between the electrodes depending on the orientation of the Burgers vector with respect to the applied electric field. Apart from the grain boundaries, where several dislocations pile up after having moved through the core grain along preferential crystal slip planes, the problem of the line defects deserves a simulation model that extends some relevant concepts of the dislocation science: are known in solid state physics phenomena like dislocation climb and jog, polygonization structures and so on.

From a theoretical point of view, the problem of ion diffusion in real lattices is so complex that simplifying assumptions are necessary. The most typical one introduces a homogeneous and isotropic ceramic lattice at constant and uniform temperature T ; in this way D is given by a unique scalar value instead of a tensor matrix. Also, the dependence of D and related conductivity σ upon T are described regardless of their microscopic correlation to the microstructure, e.g. orientation and spacing of the crystal planes with respect to the average direction of drift speed of the charge carriers. Since the present paper represents an extension of the previous results, a short reminder of [9] is useful at this point. The starting points were the mass flow equations

$$\mathbf{J} = -D\nabla c = cv : \quad (1)$$

the first equality is a phenomenological law that introduces the proportionality factor D , the latter is instead a definition consistent with the physical dimensions of matter flow i.e. $mass/(surface \times time)$. The second Fick law is straightforward consequence of the first one under the additional continuity condition, i.e. the absence of mass sinks or sources in the diffusion medium. Strictly speaking one should replace the concentration with the activity, yet for simplicity the symbol of concentration will be used in the following. The model focuses on a solid lattice of ceramic electrolyte, assumed for simplicity homogeneous and isotropic, where charge carriers are allowed to travel under concentration gradient and electric potential field. It is interesting in this respect the well known Nernst-Einstein equation linking σ to $D/k_B T$, which has general valence being inferred through elementary and straightforward thermodynamic considerations shortly commented below; so, in the case of mixed electronic-ionic conduction, it holds for ions and expectedly for electrons too, being in effect direct consequence of the Ohm law. Is known the dependence of D on T ; the Arrhenius-like form $D = D_0 \exp(-\Delta G/kT)$ via the activation free energy ΔG is due not only to the direct T -dependence of the frequency of lattice jumps inherent D_0 , but also to the fact that the temperature controls the amount

and kind of point defects that affect ΔG . The Nernst-Einstein equation has conceptual and practical importance, as it allows calculating how the electrolytes of SOFCs conduct at different temperatures; yet it also stimulates further considerations about the chance of describing the interactions of charges in a crystal lattice via the concept of “effective mass” and the concept of diffusion coefficient in agreement with the Fick laws. This point is shortly highlighted as follows.

It is known that the effective mass m^{eff} of an electron with energy E moving in a crystal lattice is defined by $m^{\text{eff}} = \hbar^2(\partial^2 E(k)/\partial k^2)^{-1}$, being $k = 2\pi/\lambda$ and λ the wavelength of its De Broglie momentum $p = h/\lambda = \hbar k$. The reason of this position is shortly justified considering the classical energy $E = p^2/2m + U$, which reads $E = \hbar^2 k^2/2m + U$ from the quantum standpoint; $U = U(k)$ is the electron interaction potential with the lattice. If in particular $U = 0$, then m^{eff} coincides with the ordinary free electron rest mass m . Instead the interacting electron is described by an effective mass $m^{\text{eff}} \neq m$; putting $U = \hbar^2 u(k)/m$ and replacing in E , one finds instead $m^{\text{eff}} = m(1 + \partial^2 u/\partial k^2)^{-1}$. In fact the deviation of m^{eff} from m measures the interaction strength of the electron with the lattice; it is also known that by introducing the effective mass, the electron can be regarded as a free particle with good approximation. Owing to the physical dimensions $length^2 \times time^{-1}$ of \hbar/m , the same as the diffusion coefficient, it is formally possible to put $D = \hbar q_m/m$ and $D^{\text{eff}} = \hbar q_m^{\text{eff}}/m^{\text{eff}}$ via appropriate coefficients q_m and q_m^{eff} able to fit the experimental values of D and D^{eff} .

Rewrite thus m^{eff}/m as

$$\frac{D^{\text{eff}}}{D^*} = 1 + \frac{\partial^2 u}{\partial k^2} \quad D = \frac{\hbar q_m}{m} \quad D^* = qD \quad q = \frac{q_m^{\text{eff}}}{q_m}, \quad (2)$$

which calculate D^* and thus D^{eff} as a function of the physical D actually measurable. So, once taking into account the interaction of the electron with the lattice, one could think that the real and effective electron masses correspond to the actual D and effective D^{eff} related to its interaction with the electric field and lattice. Note that the first eq (2) reads

$$D^{\text{eff}} = D^* + D^{\S} \quad D^{\S} = D^* \frac{\partial^2 u(k)}{\partial k^2}. \quad (3)$$

Clearly the contribution of D^{\S} to the actual diffusion coefficient D^{eff} is due to the kind and strength of interaction of the charge carrier with the lattice; thus D^{eff} , and not the plain D , has physical valence to determine the electrical conductivity of the electrolyte during the operation conditions of the cell: the electron in the lattice is not a bare free particle, but a quasi-particle upon which depends in particular its conductivity. It is known indeed that electrons in a conductor should be uniformly accelerated by an applied electric field, but attain instead a steady flow rate because of their interaction with the lattice that opposes their motion; the resistivity is due to the electron-phonon scattering and interaction with lattice ions,

impurities and defects, thermal vibrations. Any change of these mechanisms affects the resistivity; as a limit case, even the superconducting state with null resistivity is due itself to the formation of Cooper pairs mediated just by the interaction between electrons and lattice. Write thus the Nernst-Einstein equation as follows

$$\sigma^{\text{eff}} = \frac{1}{\rho^{\text{eff}}} = \frac{(ze)^2 c D^{\text{eff}}}{k_B T}. \quad (4)$$

The crucial conclusion is that all this holds in principle for any charge carrier, whatever U and m might be. To understand this point, suppose that the interaction potential U depends on some parameter, e.g. the temperature, such that $u = u(k, T)$ verifies the condition $\lim_{T \rightarrow T_c} \partial^2 u/\partial k^2 = \infty$ at a critical temperature $T = T_c$. Nothing excludes “a priori” such a chance, as this condition does not put any physical constrain on the macroscopic value of the diffusion coefficient D nor on the related D^* : likewise as this latter is simply D affected by the applied electric field via the finite factor q , the same holds for D^{eff} affected by the lattice interaction upon which depends m^{eff} as shown in the eq (2). Thus the limit $\lim_{T \rightarrow T_c} (D^{\text{eff}}/D) = \infty$ concerns D^{\S} only. Being $q_m > 0$ and $q_m^{\text{eff}} > 0$ but anyway finite, the divergent limit is not unphysical, it merely means that at $T = T_c$ the related carrier/lattice interaction implies a new non-diffusive transport mechanism; this holds regardless of the actual value of D , which still represents the usual diffusion coefficient in the case of carriers ideally free or weakly interacting with the lattice in a different way, e.g. via vacancies only. In conclusion are possible two diverse consequences of the charge carrier/lattice defect interactions: one where $D^{\S} \neq D$, i.e. the presence of defects simply modifies the diffusion coefficient, another one where the usual high temperature diffusive mechanism is replaced by a different non-diffusive mechanism characterized by $D^{\S} \rightarrow \infty$, to which corresponds $\rho^{\text{eff}} \rightarrow 0$ at $T = T_c$. Two essential remarks in this respect, which motivate the present paper, concern:

(i) The quantum origin of both eqs (1) is inferred in [10]; this paper infers both equations as corollaries of the statistical formulation of quantum uncertainty. Has been contextually inferred also the statistical definition of entropy $S = -\sum_j \pi_j \log(\pi_j)$ in a very general way, i.e. without hypotheses about the possible gaseous, liquid or solid phase of the diffusion medium. It has been shown that the driving force of diffusion is related to the tendency of a thermodynamic system in non-equilibrium state because of the concentration gradients towards the equilibrium corresponding to the maximum entropy, whence the link between diffusion propensity and entropy increase.

(ii) The result $D^{\text{eff}} = D^{\S} + D^*$, actually inferred in [9]: the interaction of the charge carrier with the stress field of one edge dislocation defines an effective diffusion coefficient D^{eff} consisting of two terms, D^* related to its interaction with the

electric potential of the cell and D^{\S} related to its chemical gradient and interaction with the stress field of the dislocation.

The concept of D^{eff} is further concerned in the next section to emphasize that the early ideas of Fick mass flow, which becomes now effective mass flow, and Einstein D^{eff} -dependent conductivity are extendible to and thus still compatible with the limit case $D^{\S} \rightarrow \infty$.

In summary $D_{id} \rightarrow D \rightarrow D^* \rightarrow D^{\text{eff}}$ are the possible diffusion coefficients of each charge carrier concerned in [9]: D_{id} is that in an ideal defect free lattice, D that in a lattice with point defects only, D^* in the given lattice with an applied electric potential, D^{eff} in a real lattice with dislocations under an applied electric potential. The chance of extrapolating the equation (4) to the superconducting state, despite this latter has seemingly nothing to do with the diffusion driven charge displacement, relies on two logical steps.

The first step is to acknowledge that $D^{\text{eff}} = D^{\S} + D$ is required by the presence of dislocations, because D^{eff} cannot be defined simply altering the value of the plain D ; the reason of it has been explained in [9] and is also summarized in the next section for clarity.

To elucidate the second step, consider preliminarily $D \rightarrow D^{\text{eff}}$ simply because $D^{\S} \gg D$: in this case the finite contribution D^{\S} due to the charge/dislocation interaction can be accepted without further problems.

Suppose that a valid physical reason allows a charge carrier to move as a free particle in the lattice, regardless of the concentration gradient or applied potential difference or force \mathbf{F} of any physical nature; in this extreme case, the condition $\rho^{\text{eff}} \rightarrow 0$ necessarily results by consequence and requires itself straightforwardly $D^{\S} \rightarrow \infty$ in the Nernst-Einstein equation. In other words, the second step to acknowledge the divergent value of D^{\S} is to identify the peculiar interaction mechanism such that the charge carrier behaves effectively in the lattice as a free particle at a critical temperature T_c : the existence of such a mechanism plainly extrapolates to the superconducting state the eq (4), which is thus generalized despite the link between σ and D is usually associated to a diffusive mechanism only.

The present paper aims to show that thanks to the fact of having introduced both point and line lattice defects in the diffusion problem, the previous model can be effectively extended to describe even the ion superconducting state in ceramic electrolytes. It is easy at this point to outline the organization of the present paper: the section 2 shortly summarizes the results exposed in [9], in order to make the exposition clearer and self-contained; the sections 3 and 4 concern the further elaboration of these early results according to the classical formalism. Eventually the section 5 reviews from the quantum standpoint the concepts elaborated in section 4. Thus the first part of the paper concerns in particular the usual mechanism of charge transport via ion carriers, next the results are extended to the possible superconductivity effect described in the section 5. A preliminary simulation test

in the section 5.1 will show that the numerical results of the model in the particular case where the charge carrier is just the electron match well the concepts of the standard theory of superconductivity.

2 Physical background of the model

The model [9] assumes a homogeneous and isotropic electrolyte of ceramic matter at uniform and constant temperature everywhere; so any amount function of temperature can be regarded as a constant. The electrolyte is a parallelepiped, the electrodes are two layers deposited on two opposite surfaces of the parallelepiped. The following considerations hold for all charge carriers; for simplicity of notation, the subscript i that numbers the i -th species will be omitted. Some remarks, although well known, are shortly quoted here because useful to expose the next considerations in a self-contained way. Merging the flux definition $\mathbf{J} = c\mathbf{v}$ and the assumption $\mathbf{J} = -D\nabla c$ about the mass flux yields $\mathbf{v} = -D\nabla \log(c)$. Introduce then the definition $\mathbf{v} = \beta\mathbf{F}$ of mobility β of the charge carrier moving by effect of the force \mathbf{F} acting on it; one infers both $D = k_B T \beta$ and $\mathbf{F} = -\nabla\mu$ together with $\mu = -k_B T \log(c/c_o)$. An expression useful later is

$$\mathbf{F} = \frac{k_B T}{D} \mathbf{v} = \frac{k_B T}{Dc} \mathbf{J}. \quad (5)$$

So the force is expressed through the gradient of the potential energy μ , the well known chemical potential of the charge carrier. The arbitrary constant c_o is usually defined as that of equilibrium; when c is uniform everywhere in the diffusion medium, the driving force of diffusion vanishes and the Fick law predicts a null flow of matter, which is consistent with $c \equiv c_o$. Another important equation is straightforward consequence of the link between mass flow and charge flow; since the former is proportional to the number of charged carriers, each one of which has charge ze , one concludes that $\mathbf{J}_{ch} = ze\mathbf{J}$ and so $\beta_{ch} = ze\beta$. Let the resistivity ρ be summarized macroscopically by Ohm's law $\rho\mathbf{J}_{ch} = -\nabla\phi = \mathbf{E}$; i.e. the charge carrier interacts with the lattice while moving by effect of the applied electric potential ϕ and electric field \mathbf{E} . The crucial eq (4) is inferred simply collecting together all statements just introduced in the following chain of equalities

$$\begin{aligned} \mathbf{J}_{ch} &= \sigma\mathbf{E} = zec\mathbf{v} = zec\beta_{ch}\mathbf{E} = \\ &= (ze)^2 c\beta\mathbf{E} = \frac{(ze)^2 \mathbf{E} c D}{k_B T} = -\frac{c D z e \nabla \phi}{k_B T}. \end{aligned} \quad (6)$$

Moreover the effect of an electric field on the charge carriers moving in the electrolyte is calculated through the last sequence of equalities recalling that the electric and chemical forces are additive. Consider thus the identity

$$\mathbf{F}_{tot} = -\nabla\mu - \alpha ze \nabla\phi = -\frac{k_B T}{c} \left(\nabla c + \alpha \frac{ze c \nabla\phi}{k_B T} \right)$$

where α is the so called self-correlation coefficient ranging between 0.5 to 1; although usually taken equal to 1 and omitted [11], it is quoted here by completeness only. Recalling the mobility equation $k_B T/c = D/\beta c$ and noting that $\mathbf{F}\beta c$ is just a mass flow, the result is

$$\mathbf{J}_{tot} = -D \left(\nabla c + \alpha \frac{z e c}{k_B T} \nabla \phi \right) = \frac{c D}{k_B T} (\nabla \mu - \alpha z e \nabla \phi). \quad (7)$$

So far D has been introduced without mentioning the diffusion medium, in particular as concerns its temperature and the presence of lattice defects of the ceramic crystal. As the point defects simply increase the frequency of lattice jumps [12] and thus the value of the diffusion coefficient, in these equations D is assumed to be just that already accounting for the vacancy driven enhancement. As concerns the presence of edge and screw dislocations also existing in any real crystal, the paper [9] has shown that in fact the dislocations modify significantly the diffusion mechanism in the electrolyte: their stress field hinders or promotes the charge transfer by creating preferential paths depending on the orientation of the dislocation stress field with respect to the electrode planes. In particular the dislocation affects the mobility of the charge carriers, as it is intuitive to expect: phenomena like the climbing, for instance, occur when a dislocation or isolated atoms/ions move perpendicularly to the extra plane of another dislocation to overcome the compression field due to the local lattice distortion. Moreover, in the case of edge dislocations the figure 2 shows the possibility of confinement of light atoms, e.g. typically C and N, along specific lattice directions perpendicular to the Burgers vector; this emphasizes the importance of the orientation of grains and dislocations with respect to the average path of the charges between the electrodes.

Assume first one lonely dislocation in a single crystal lattice; this case allows a preliminary assessment of the interaction between charge carriers travelling the lattice in the presence of an applied potential field. In the case of edge dislocation the shear stress component on a plane at distance y above the slip plane is known to be $\sigma_{xy} = [8\pi y(1-\nu)]^{-1} G b \sin(4\theta)$, being ν the Poisson modulus, G the shear modulus, $b = |\mathbf{b}|$ and \mathbf{b} the Burgers vector, θ is the lattice distortion angle induce by the extra plane on the neighbour crystal planes [13]. Moreover the modulus of the force per unit length of such dislocation is $F^{(d)} = b \sigma_{xy}$, where the superscript stands for dislocation. Hence, calling $l^{(d)}$ the length of the extra plane, the force field due to one dislocation is

$$\mathbf{F}^{(d)} = [8\pi y(1-\nu)]^{-1} G b^2 l^{(d)} \sin(4\theta) \mathbf{u}_b$$

where \mathbf{u}_b is a unit vector oriented along the Burger vector, i.e. normally to the dislocation extra plane. It is known that atom exchange is allowed between dislocations; the flow \mathbf{J} of these atoms within a lattice volume Ω is reported in the literature to be

$$\mathbf{J} = D_L \nabla \mu / (\Omega k_B T) \quad \mu = -kT \log(c_\Omega),$$

being μ the chemical potential and D_L the appropriate diffusion coefficient; for clarity are kept here the same notations of the original reference source [14]. Actually this flow is straightforward consequence of the Fick law, as it appears noting that the mass m_Ω of atoms within the volume Ω of lattice corresponds by definition to the average concentration $c_\Omega = m_\Omega/\Omega$; so the atom flow between dislocations at a mutual distance consistent with the given Ω is nothing else but the diffusion law $\mathbf{J}_\Omega = -D_L \nabla c_\Omega$ itself, as it is shown by the following steps

$$\begin{aligned} \mathbf{J}_\Omega &= -D_L \nabla c_\Omega = -c_\Omega D_L \nabla \log(c_\Omega) \\ &= \frac{c_\Omega D_L}{k_B T} \nabla \mu = \frac{m_\Omega}{\Omega} \frac{D_L}{k_B T} \nabla \mu. \end{aligned} \quad (8)$$

Thus the flow $\mathbf{J} = \mathbf{J}_\Omega/m_\Omega$ reported in the literature describes the number of atoms corresponding to the pertinent diffusing mass. The key point of the reasoning is the appropriate definition of the diffusion coefficient D_L , which here is that of a cluster of atoms of total mass m_Ω rather than that of one atom in a given matrix. Once having introduced $\mathbf{F}^{(d)}$, it is easy to calculate how the flow of the charge carriers is influenced by this force field via the related quantities $D^{(d)} = k_B T \beta^{(d)}$ and $\mathbf{v}^{(d)} = \beta^{(d)} \mathbf{F}^{(d)}$; in metals, for instance, it is known that the typical interaction range of a dislocation is of the order of 10^{-4} cm [13]. The contribution of this exchange to the charge flow is reasonably described by $\mathbf{J}^{(d)} = \mathbf{F}^{(d)} D^{(d)} c/k_B T$ according to the eq (5). Consider now $\mathbf{F}^{(d)}$ as the average field due to several dislocations, while the same holds for $\beta^{(d)}$ and $D^{(d)}$, which are therefore related to the pertinent $\sigma^{(d)}$; omitting the superscript to simplify the notation, eq (7) reads thus

$$\begin{aligned} \mathbf{J}_{tot} &= -D \left(\nabla c + \alpha \frac{z e c}{k_B T} \nabla \phi - \frac{c \mathbf{F}}{k_B T} \right) \\ \mathbf{F} &= \langle \mathbf{F}^{(d)}(G, \nu, l^{(d)}, \mathbf{b}) \rangle. \end{aligned} \quad (9)$$

In this equation D has the usual statistical meaning in a real crystal lattice and includes the electric potential as well. Here the superscript has been omitted because also \mathbf{F} denotes the statistical average of all the microscopic stress fields $\mathbf{F}^{(d)}$ existing in the crystal. One finds thus with the help of the continuity condition

$$\nabla \cdot \left[D \left(\nabla c + \alpha \frac{z e c}{k_B T} \nabla \phi - \frac{c \mathbf{F}}{k_B T} \right) \right] = \frac{\partial c}{\partial t} \quad D = D(T, c, t) \quad (10)$$

where c and \mathbf{v} are the resulting concentration and drift velocity of the i -th charge carrier in the electrolyte. In general the diffusion coefficient depends on the local chemical composition and microstructure of the diffusion medium. Moreover the presence of \mathbf{F} into the general diffusion equation is required to complete the description of the charge drift through a real ceramic lattice by introducing a generalized thermodynamic force, justified from a microscopic point of view and

thus to be regarded also as a statistical macroscopic parameter. This force, considered here as the average stress field resulting from the particular distribution of dislocation arrays in the lattice, accounts for the interaction of a charge carrier with the actual configuration of lattice defects and is expected to induce three main effects: (i) to modify the local velocity \mathbf{v} of the charge carrier, (ii) to modify the local concentration of the carriers (recall for instance the ‘‘Cottrell atmospheres’’ that decorate the dislocation), (iii) to modify the local electric potential because altering the concentration of charged particles certainly modifies the local ϕ . Accordingly, considering again the average effects of several dislocations in a macroscopic crystal, it is reasonable to write

$$\frac{c\mathbf{F}}{k_B T} = \frac{mc\dot{\mathbf{v}}}{k_B T} + a\nabla c + \mathbf{\Gamma}$$

$$\dot{\mathbf{v}} = \dot{\mathbf{v}}(c) \quad \mathbf{\Gamma} = \mathbf{\Gamma}(c, \phi_o) \quad c = c(x, y, z, t, T)$$

being a a proportionality constant. The first addend at right hand side accounts for the effect (i), the second for the effect (ii), the vector $\mathbf{\Gamma}$ for the effect (iii) because it introduces the local potential ϕ_o due to the charges piled up around the dislocation; the dependence of these quantities on c of the pertinent carrier emphasizes the local character of the respective quantities depending on the time and space coordinates. The final step is to guess the form of $\mathbf{\Gamma}$ in order to introduce in the last equation the electrochemical potential $\alpha\phi + \mu/ze$ inferred from the eq (7). As motivated in [9], $\mathbf{\Gamma}$ is defined as a local correction of ϕ because of the concentration of the charge carriers; with the positions

$$\mathbf{\Gamma} = \frac{c\alpha}{k_B T} \nabla(ze\phi + \mu) - \frac{ze\phi_o\alpha}{k_B T} \nabla c \quad a = 1 - \alpha$$

eq (10) turns into

$$\nabla \cdot \left[\frac{m\mathbf{v}}{k_B T} \frac{\partial(cD)}{\partial t} + \frac{ze\phi_o\alpha}{k_B T} D\nabla c \right] = \frac{\partial C}{\partial t} \quad (11)$$

where

$$C = c + \frac{m}{k_B T} \nabla \cdot (cD\mathbf{v}) \quad \phi_o = \phi_o(x, y, z, t).$$

The function ϕ_o has physical dimensions of electric potential. Eventually, owing to this definition of C , the last equation reads

$$\nabla \cdot [(D^* + D^{\S})\nabla C] = \frac{\partial C}{\partial t} \quad (12)$$

being

$$D^* = \frac{ze\phi_o}{k_B T} \alpha D \quad \frac{m}{k_B T} \frac{\partial(cD)}{\partial t} \mathbf{v} = D^* \nabla(C - c) + D^{\S} \nabla C.$$

These considerations show that it is possible to define an effective diffusion coefficient in the presence of an applied potential ϕ and taking into account the presence of point and line defects

$$D^{\text{eff}} = D^* + D^{\S}. \quad (13)$$

This equation is equal to that inferred via the effective mass of the charge carrier interacting with the lattice, see the eq (3); D^{\S} is defined by the last eq (12) accounting via C for the presence of dislocations in a real ceramic electrolyte. Accordingly, the equation (13) is modified as follows

$$\frac{D^{\text{eff}}}{D} = \alpha \frac{ze\phi_o}{k_B T} + \frac{D^{\S}}{D} \quad \sigma^{\text{eff}} = \frac{1}{\rho^{\text{eff}}} = \frac{D^{\text{eff}}}{D} \sigma. \quad (14)$$

The solution of the eq (10) via the eq (12) to find the analytical form of the space and time profile of c is described in [9]; it is not repeated here because inessential for the purposes of the present paper. Have instead greater importance the result (13) and the following equations inferred from the eqs (11) and (12)

$$\nabla \cdot (cD\mathbf{v}) = 0, \quad C \equiv c, \quad \mathbf{v} = \frac{k_B T}{m} \frac{D^{\S}}{\partial(cD)/\partial t} \nabla c. \quad (15)$$

The consistency of the first equation with the eq (12) has been therein shown. This condition requires that the vector $cD\mathbf{v}$, having physical dimensions of energy per unit surface, is solenoidal i.e. the net flow of carriers crossing the volume enclosed by any surface is globally null; this holds for all carriers and means absence of source or sinks of carriers around any closed surface. Note that this condition is fulfilled by

$$\mathbf{v} = \frac{\mathbf{B}}{cD} \quad (16)$$

with

$$\mathbf{B} = \mathbf{i}B_x(y, z, t) + \mathbf{j}B_y(x, z, t) + \mathbf{k}B_z(x, y, t) \quad |\mathbf{B}| \rightarrow \frac{\text{energy}}{\text{surface}}.$$

The vector \mathbf{B} is defined by arbitrary functions whose arguments depend on the coordinate variables as shown here: at any time and local coordinates the functions expressing the components of \mathbf{B} can be appropriately determined in order to fit the corresponding values of $\mathbf{v}cD$ resulting from the solution of the eq (10). Hence the positions (15) do not conflict with this solution, whatever the analytical form of \mathbf{v} and c might be; the third equality (15) defines $D^{\S} = D^{\S}(c, D, \mathbf{v}, T)$. The central result to be implemented in the present model is

$$\mathbf{v} = \frac{k_B T}{\eta} D^{\S} \frac{\nabla c}{m} = \Omega D^{\S} \nabla n \quad (17)$$

where

$$\eta = \frac{\partial(cD)}{\partial t} \quad n = \frac{c}{m} \quad \Omega = \frac{k_B T}{\eta}$$

with n numerical density of the given carrier and η energy density corresponding to the time change of cD ; the volume Ω results justified by dimensional reasons and agrees with the fact that the diffusion process is thermally activated. Moreover one finds

$$\mathbf{v} = \frac{\mathbf{B}}{cD} = \frac{\Omega}{m} D^{\S} \nabla c = D^{\S} \frac{\nabla c}{c} \quad m = c\Omega. \quad (18)$$

Owing to the importance of the third eq (15) for the purposes of the present paper, it appears useful to verify its validity; this check is shortly sketched below by demonstrating its consistency with relevant literature results.

First of all, the eq (17) leads itself to the literature result (8); the key points are the definition of mobility β and its relationship to the diffusion coefficient $\beta = D/kT$ previously reported in the eq (5). Let the atom exchange between dislocations be thermally activated, so that holds the last eq (17). Being $\mathbf{v} = D^{\S} \nabla \mu / k_B T$ according to the eq (18), then $D_L \mathbf{F} / k_B T = -D^{\S} \nabla \mu / k_B T$ specifies $D_L \equiv D^{\S}$, i.e. the diffusion coefficient is that pertinent to the interaction of atoms with the concerned dislocations; moreover the force $\mathbf{F} \equiv -\nabla \mu$ acting on the atoms corresponds to the change of chemical potential related to the migration of the atoms themselves. Since these relationships are directly involved in the Fick equation inferred in section 1, it follows that the eq (15) fits well the model of concentration gradient driven diffusion process.

Furthermore let us show that eq (15) implies the link between $\nabla \mu$ and the stress τ that tends to move preferentially dislocations with Burgers vector favourably oriented in a crystal matrix, e.g. perpendicularly to a tilt boundary plane [14]; this stress produces thus a chemical potential gradient between adjacent dislocations having non-perpendicular component of the Burgers vector. Once more D to be implemented here is just the diffusion coefficient D^{\S} pertinent to the interaction with the dislocation and thus appropriate to this specific task. Assuming again $k_B T / \eta \approx \Omega$, then $\mathbf{F} = -\nabla \mu$ yields $\mathbf{F} \Omega = -(k_B T / \eta) \nabla \mu$. If two dislocations are at a distance d apart, then $\Omega = Ad/2$ for each dislocation, being A the surface defined by the length L of the dislocations and the height of their extra-planes; so Ad is the total volume of matrix enclosed by them, whereas $Ad/2$ is the average volume defined by either extra-plane and its average distance from an equidistant atom, assumed $d/2$ apart from each dislocation. Being $2\mathbf{F} \Omega / (Ad) = -\nabla \mu$, the conclusion is that $2\tau \Omega / d = -\nabla \mu$ with $\tau = \mathbf{F} / A$, which is indeed the result reported in [14].

Finally let us calculate with the help of the eq (15) also the atom flux $\mathbf{I} = A \mathbf{J} / m$ between dislocations per length of boundary of cross section A in direction parallel to the tilt axis. The following chain of equations

$$\begin{aligned} \mathbf{I} &= -\frac{AD_L \nabla c}{m} = -\frac{AD_L \nabla c}{c \Omega} = -\frac{AD_L \nabla \log(c)}{\Omega} = \\ &= \frac{D_L A \nabla \mu}{k_B T \Omega} = -\frac{2D_L \mathbf{F}}{k_B T d} = -\frac{2D_L L \tau}{k_B T} \quad \tau = \frac{\mathbf{F}}{Ld} \end{aligned}$$

yields the literature result $-2D_L \tau / kT$ per unit length of dislocation [14].

All considerations carried out from now on are self-contained whatever the analytical form of c might be. In the following the working temperature T of the cell is always regarded as a constant throughout the electrolyte.

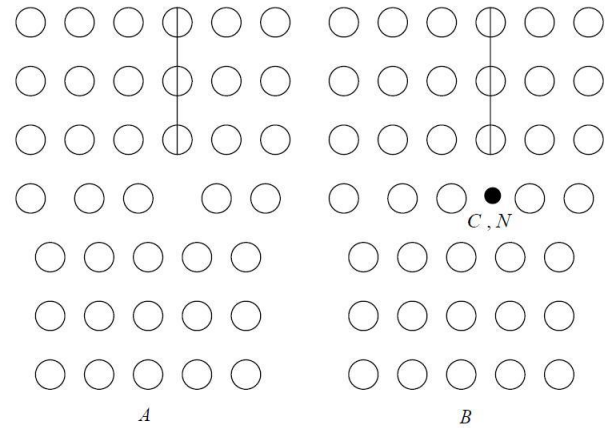

Fig. 2: A: Cross section of the stretched zone of an edge dislocation at the interface between the lower boundary of the extra plane and the perfect lattice. B: Equilibrium position of an atom, typically carbon or nitrogen, in the stretched zone after stress ageing.

3 Outline of the charge transport model

In general, the macroscopic charge flow within the electrolyte of a SOFC cell is statistically represented by average concentration profiles of all charges that migrate between the electrodes. The profiles of the ions during the working condition of the cell, qualitatively sketched in the fig. 1, are in effect well reproduced by that calculated solving the diffusion equation (12) [9]. The local steps of these paths consist actually of random lattice jumps dependent on orientation, structure and possible point and line defects of the crystal grains forming the electrolyte, of course under the condition that the displacement of the charge carriers must be anyway consistent with the overall formation of neutral reaction products. So \mathbf{v} and ∇n of the eqs (17) are average vectors that consist actually of local jumps dependent on how the charge carriers interact each other and with lattice defects, grain boundaries and so on. The interaction of low sized light atoms and ions with the lattice distortion due to the extra plane of a dislocation has been concerned in several papers, e.g. [15]: the figure 2A shows the cross section of the stretched zone of an edge dislocation, the fig. 2B the location of a carbon atom in the typical configuration of the Cottrell atmosphere after strain ageing of bake hardenable steels. The segregation of N and C atoms, typically interstitials, on dislocations to form Cottrell atmospheres is a well known effect; it is also known that after forming these atmospheres, energy is required to unpin the dislocations: Luders bands and strain ageing are macroscopic evidences of the pinning/unpinning instability. These processes are usually activated by temperature and mechanical stresses.

Of course the stress induced redistribution and ordering of carbon atoms has 3D character and has been experimentally

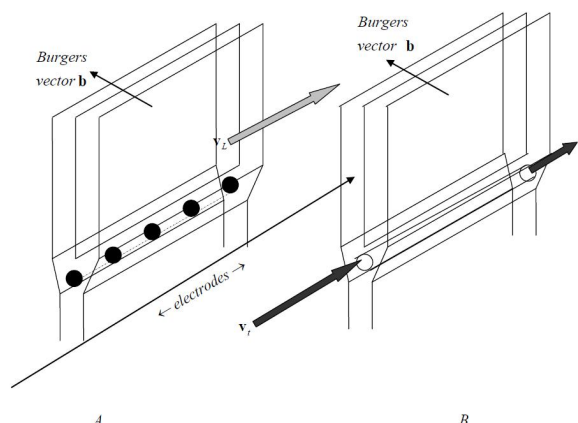

Fig. 3: 3D representation of the static Cottrell configuration of several carbon atoms after interaction with the stress field of an edge dislocation. B: dynamical flow of charge carriers that tunnel along the length of the extra plane of the dislocation.

verified in ultra low carbon steels; the configuration reported in the literature and redrawn in fig 3A explains the return to the sharp yield point of the stress-strain curve of iron [16].

The chance that light atoms line up into the strained zone of an edge dislocation is interesting for its implications in the case of mixed conductivity in ceramic electrolytes. It is reasonable to guess that the aligned configuration sketched in fig. 3A is in principle also compatible with the path of mobile charge carriers displacing along this transit trail, as represented in the fig. 3B. Among all possible paths, the next section concerns in particular the conduction mechanism that occurs when low atomic number ions tunnel along the stretched zone at the interface between the extra-plane of an edge dislocation and the underlying perfect lattice. The mechanism related to this specific configuration of charges involves directly the interaction of the carriers with the dislocation and thus is described by the eq (15), which indeed depends explicitly upon D^{\S} . From a classical point of view, is conceivable in principle an ideal fuel cell whose electrolyte is a ceramic single crystal with one edge dislocation spanning the entire distance between the electrodes; in this particular case, therefore, is physically admissible a double conduction mechanism based on the standard diffusive process introduced in [9] plus that of ion tunnelling throughout the whole electrolyte size. Regarding the tunnel path and the whole lattice path as two parallel resistances, the Kirchhoff laws indicate how the current of charge carriers generated at the electrodes shunts between either of them. This is schematically sketched in the figure 4.

The tunnel mechanism appears reasonable in this context considering the estimated electron and proton classical radii, both of the order of 10^{-15} m, in comparison with the lattice

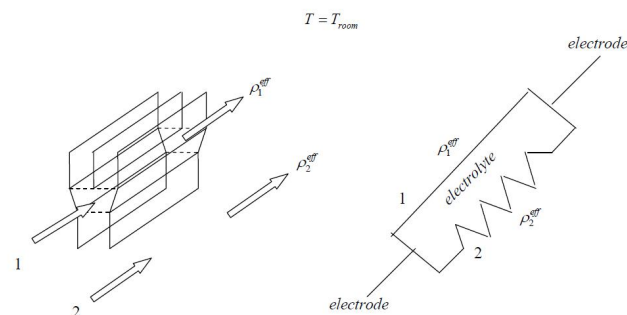

Fig. 4: Shunt effect of charge carriers between dislocation path and lattice path of different resistivity. On the left is sketched the possible path within and in proximity of the stretched zone of an edge dislocation; on the right is shown the corresponding electric circuit of the currents crossing the electrolyte.

spacing, of the order of some 10^{-10} m. A short digression about the atom and ion sizes with respect to the crystal cell parameter deserves attention. Despite neither atoms nor ions have definite sizes because of their electron clouds lack sharp boundaries, their size estimate allowed by the rigid sphere model is useful for comparison purposes; as indeed the Cottrell atmospheres of C and N atoms have been experimentally verified, the sketch of the fig. 3A suggests by size comparison a qualitative evaluation about the chance of an analogous behaviour of ions of interest for the fuel cells. The atomic radius is known to be in general about 10^4 times that of the nucleus, the radii of low atomic number elements typically fall in the range $1 \div 100$ pm [17]. Specifically, the covalent values for C, N and O atoms are 70, 65 and 60 pm respectively; it is known that they decrease across a period. The ionic radii of low atomic number elements are typically of the order of 100 pm [18]; they are estimated to be 0.1 and 0.14 nm for Na^+ and O^{\ominus} . It is known that the average lattice parameters of solid oxides increase about linearly with cationic radii [19]; typical values of lattice average spacing are of the order of 0.5-0.6 nm. As the stretched zone of a dislocation has size necessarily greater than the unstrained spacing, one reasonably concludes that, at least in principle, not only the proton and nitrogen and carbon atoms but even oxygen ions have sizes compatible with the chance of being accommodated in the stretched zone underlying the dislocation extra-plane. These estimates suggest by consequence that even low atomic number ion conduction via channelling mechanism along the stretched zone of the dislocation is reasonably possible. It is known that proton conducting fuel cells typically work with protons crossing of polymer membranes from anode to cathode, whereas in-SOFCs oxygen ions migrate through the ceramic electrolyte from cathode to anode; yet the tunnelling mechanism seems in principle consistent with both kinds of charge carriers in typical SOFC electrolytes.

Consider now the case where the driving energy of the segregation process of atoms to dislocations is not only the lattice strain of the ceramic electrolyte but, during the working cycle of a fuel cell, also the free energy that generates ions at the electrodes and compels them migrating by effect of the electric potential; the alignment of several ions confined along the dislocation length sketched in fig. 3A has thus a dynamical valence, i.e. it suggests the specific displacement mechanism that involves the tunnelling of ions throughout the stretched zone of an edge dislocation at its boundary with the perfect lattice. In other words, one can think that the line of foreign light ions along this zone is also compatible with the particular migration path of such ions generated at either electrode; certainly the proton is a reasonable example of carrier compliant with such particular charge transport mechanism, as qualitatively sketched in fig. 3B. These considerations explain the difference between D , the usual diffusion coefficient of a given ion in a given lattice with or without point defects, and D^{eff} , which in this case is the effective diffusion coefficient of the same ion that moves confined in the stretched zone of the dislocation. This conclusion agrees with and confirms the idea that the electric conductivity is related to D^{eff} and not to D , because the former only accounts for this particular kind of interaction between charge carrier and dislocation. Also, just for this reason in the fig. 4 the resistivity of ions with different kind of interaction with the dislocation, i.e. inside it along the stretched zone and outside it in the lattice compression zone, have been labelled respectively ρ_1^{eff} and ρ_2^{eff} . Despite D^{eff} is related generically to any interaction mechanism possible when charge carriers move in the presence of dislocations, it will be regarded in the following with particular reference to the charge tunnelling mechanism just introduced.

4 Classical approach to elaborate the early results [9]

The experimental situation described in this section, in principle possible, is the one of a unique edge dislocation crossing throughout the single crystal ceramic electrolyte and arbitrarily inclined with respect to plane parallel electrodes. The following discussion concerns the eq (17) and consists of two parts: the first part has general character, i.e. it holds at any point of the ceramic lattice, in which case the presence of the dislocation merely provides a reference direction to define specific components of \mathbf{v} ; the second part aims to describe the particular mechanism of transport of charges that tunnel along the stretched zone of the dislocation, which in fact is the specific case of major interest for the present model.

4.1 Charge transport in the electrolyte lattice

Regard in general the drift velocity \mathbf{v} of a charge carrier as due to a component \mathbf{v}_{\parallel} parallel to the tunnelling direction and a component \mathbf{v}_{\perp} perpendicular to \mathbf{v}_{\parallel} ; so the eq (17) yields

$$\mathbf{v} = \mathbf{v}_{\parallel} + \mathbf{v}_{\perp} \quad \mathbf{v}_{\parallel}\eta = k_B T D_{\parallel}^{\S} \nabla n \pm \eta' \mathbf{v}_a \quad (19)$$

$$\mathbf{v}_{\perp}\eta = k_B T D_{\perp}^{\S} \nabla n \mp \eta' \mathbf{v}_a \quad D_{\parallel}^{\S} + D_{\perp}^{\S} = D^{\S}$$

where η' has physical dimensions of energy per unit volume and \mathbf{v}_a is an arbitrary velocity vector: with the given signs, the third equation is fulfilled whatever \mathbf{v}_a and η' might be. Of course the components of \mathbf{v} are linked by

$$\mathbf{v} = \sqrt{v_{\parallel}^2 + v_{\perp}^2} \quad \mathbf{v}_{\perp} = \left(\mathbf{u}_{\parallel} - \frac{\mathbf{u}_o}{\mathbf{u}_o \cdot \mathbf{u}_{\parallel}} \right) v_{\parallel} \quad \mathbf{u}_{\parallel} = \frac{\mathbf{v}_{\parallel}}{v_{\parallel}} \quad (20)$$

with $v = |\mathbf{v}|$ given by the solution of the set (12) of diffusion equations; the same notation holds for the moduli v_{\parallel} and v_{\perp} . The arbitrary unit vector \mathbf{u}_o is determined in order to satisfy the first equation; trivial manipulations yield indeed

$$v = \frac{v_{\parallel}}{\cos \varphi} \quad v_{\perp}^2 = v_{\parallel}^2 \left(\frac{1}{\cos^2 \varphi} - 1 \right) \quad \mathbf{u}_o \cdot \mathbf{u}_{\parallel} = \cos \varphi, \quad (21)$$

which fits v^2 via an appropriate value of $\cos \varphi$. Moreover the eq (17) yields

$$v_{\parallel} = \Omega D^{\S} \mathbf{u}_{\parallel} \cdot \nabla n, \quad (22)$$

which in principle is fulfilled by an appropriate value of Ω whatever the actual orientation of \mathbf{u}_o and related value of $\cos \varphi$ in the eqs (21) might be. Consider now that also the thermal energy $k_B T = m v_T^2 / 2$ contributes to the velocity of the carriers crossing the electrolyte, and thus must somehow appear in the model; v_T defined in this way is the average modulus of the velocity vector \mathbf{v}_T , whose orientation is by definition arbitrary and random. During the working conditions of the cell it is reasonable to expect that the actual dynamics of charge transport is described combining \mathbf{v}_T , due to the heat energy of the carrier in the electrolyte, with \mathbf{v} , due to its electric and concentration gradient driving forces. Let us exploit \mathbf{v}_a of the eqs (19) to introduce into the problem just the vector \mathbf{v}_T of the carriers; hence

$$\mathbf{v}_{\parallel} = \frac{D_{\parallel}^{\S}}{D^{\S}} \mathbf{v} \pm \frac{\eta'}{\eta} \mathbf{v}_T \quad \mathbf{v}_{\perp} = \frac{D_{\perp}^{\S}}{D^{\S}} \mathbf{v} \mp \frac{\eta'}{\eta} \mathbf{v}_T \quad \mathbf{v}_a \equiv \mathbf{v}_T. \quad (23)$$

These equations express the components of \mathbf{v} along the tunnel direction and perpendicularly to it. Of course \mathbf{v} is the actual velocity of the charge carrier resulting from the solution of the eq (12), \mathbf{v}_{\parallel} and \mathbf{v}_{\perp} are the components of \mathbf{v} affected by the thermal perturbation consequently to either sign of \mathbf{v}_T ; the notations $\mathbf{v}_{\parallel}^{\pm}$ and \mathbf{v}_{\perp}^{\mp} , in principle more appropriate, are implied and omitted for simplicity. So in general

$$\mathbf{v}_{\parallel} = r_{\parallel} \mathbf{v} \pm r \mathbf{v}_T \quad \mathbf{v}_{\perp} = r_{\perp} \mathbf{v} \mp r \mathbf{v}_T \quad r = \frac{\eta'}{\eta} \quad r_{\parallel} = \frac{D_{\parallel}^{\S}}{D^{\S}} \quad (24)$$

$$r_{\perp} = \frac{D_{\perp}^{\S}}{D^{\S}} \quad r_{\parallel} + r_{\perp} = 1.$$

As expected, the velocity components result given by the respective linear combinations of \mathbf{v} and \mathbf{v}_T . Here it is reasonable to put $r = 1$ in order that $\mathbf{v}_{\parallel} \rightarrow \pm \mathbf{v}_T$ and $\mathbf{v}_{\perp} \rightarrow \mp \mathbf{v}_T$ for

$\mathbf{v} \rightarrow 0$; as this reasonably occurs for $T \rightarrow 0$, it means that both components of \mathbf{v} tend to the respective values consistent with the zero point energy of the charge carrier. Note in particular that the second eq (24) $\mathbf{v}_T = \pm(r_{\perp}\mathbf{v} - \mathbf{v}_{\perp})$ yields thanks to the eqs (21) $v_T^2 = (r_{\perp}v)^2 + v_{\perp}^2 - 2r_{\perp}\mathbf{v} \cdot \mathbf{v}_{\perp}$, i.e.

$$v_T^2 = r_{\perp}^2 \frac{v_{\parallel}^2}{\cos^2\varphi} + v_{\parallel}^2 \tan^2\varphi - 2r_{\perp}v_{\perp}^2 = \quad (25)$$

$$= \left(\frac{r_{\perp}^2}{\cos^2\varphi} + (1 - 2r_{\perp})\tan^2\varphi \right) v_{\parallel}^2 \quad \mathbf{v} \cdot \mathbf{v}_{\perp} = v_{\perp}^2$$

Let us specify now the considerations hitherto carried out to describe the behaviour of a charge carrier moving inside the stretched zone of the dislocation; the next part of this section concerns in particular just the charge transport via tunnelling mechanism.

4.2 Charge transport along the stretched zone of the dislocation

Both possible chances $r_{\parallel}\mathbf{v}_{\parallel} + \mathbf{v}_T$ and $r_{\parallel}\mathbf{v}_{\parallel} - \mathbf{v}_T$ of the first equation (24) yield an average velocity vector still consistent with the possible tunnelling of the ion. The corresponding chances of the second equation, where instead the vector \mathbf{v}_T sums and subtracts to $r_{\perp}\mathbf{v}_{\perp}$, are more interesting and critical. The components $r_{\perp}\mathbf{v}_{\perp} \mp \mathbf{v}_T$ of \mathbf{v} show indeed that the thermal agitation summed up to the transverse component of ion velocity could possibly avert the tunnelling conduction mechanism; this linear combination implies the possibility for the ion path to deviate from the tunnel direction and flow outwards the tunnel. Moreover, even the Coulomb interaction of the carriers with the charged cores of the lattice closely surrounding the tunnel is to be considered: as the cores are in general electrically charged, their interaction with the flow of mobile carriers is expectable. The second condition for a successful tunnelling path of the carriers concerns just this interaction: if for instance the charge carrier is an electron, it is likely attracted to and thus neutralizes with the positive cores; so the tunnel path through the whole distance L is in practice impossible. If instead the carrier is a proton, its Coulomb repulsion with the positive cores is consistent with the chance of travelling through L and coming out from the dislocation tunnel: in the case of a ceramic single crystal and dislocations crossing throughout it, the charge carrier would start from one electrode and would reach the other electrode entirely in the confined state. This tunnel transport mechanism is coupled with the usual lattice transport mechanism. This situation is represented in the figure 5.

Let us analyze both effects. Let $\delta t = L/v_{\parallel}$ be the time necessary for the carrier to tunnel throughout the length L of the stretched zone. Then, as schematically sketched in fig. 6, all possible trajectories are included in a cone centred on the entrance point of the carrier whose basis has maximum total size $2\delta r = 2(r_{\perp}v_{\perp} + v_T)\delta t$.

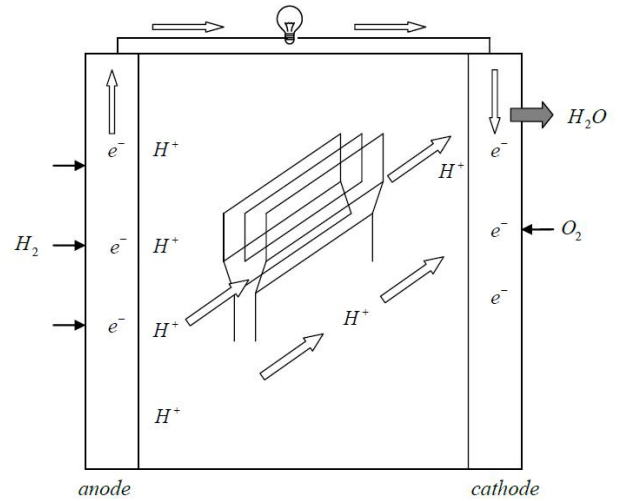

Fig. 5: Schematic sketch of a cell where is operating the proton conduction mechanisms.

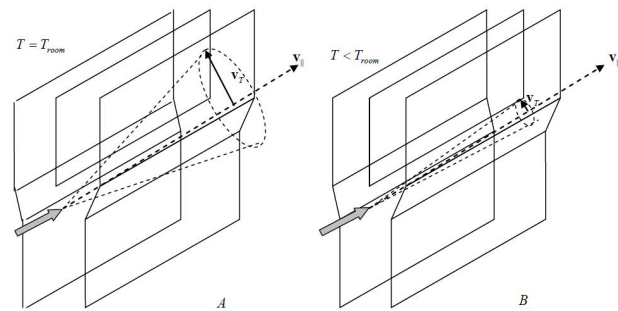

Fig. 6: The figure shows qualitatively the effect of the thermal velocity, solid arrow, on the tunnelling of a charge carrier that travels within the stretched zone of an edge dislocation. In A the vector sum of \mathbf{v}_{\parallel} and \mathbf{v}_T occurs at a temperature preventing the chance for the carrier to tunnel throughout the dislocation length; in B the reduced value of \mathbf{v}_T at lower T allows the tunnelling effect.

As \mathbf{v}_T has by definition random orientation, here has been considered the most unfavourable case where \mathbf{v}_T is oriented just transversally to \mathbf{v}_{\parallel} in assessing the actual chance of confinement of the carrier within the stretched zone of the dislocation. In general the tunnel effect is expectable at temperatures appropriately low only, in order that the width of the cone basis be consistent with the average size δl of the stretched zone: during δt the total lateral deviation $2\delta r$ of the ion path with respect to \mathbf{v}_{\parallel} must not exceed δl , otherwise the ion would overflow in the surrounding lattice. In other words, the charge effectively tunnels if v_{\parallel} is such to verify the condition $(r_{\perp}v_{\perp} + v_T)L/v_{\parallel} \leq \delta l$ only.

In conclusion, considering the worst case with the plus sign where \mathbf{v}_T and $r_{\perp}\mathbf{v}_{\perp}$ sum up correspondingly to the maximum

deviation of the charge, it must be true that, whatever the component v_{\parallel} of the actual ion displacement velocity might be,

$$T \leq \frac{m}{2k_B} \left(v_{\parallel} \frac{\delta l}{L} - r_{\perp} v_{\perp} \right)^2 \quad k_B T = \frac{m v_T^2}{2}. \quad (26)$$

Two interesting equations are obtained merging the general eq (5) and the eqs (24). Specifying for instance that the modulus of velocity is v_{\perp} and D is actually D_{\perp}^{\S} , one finds $D_{\perp}^{\S} = v_{\perp} k_B T / F_{\perp}$; so, multiplying both sides by v_{\perp} / D^{\S} and repeating identical steps also for v_{\parallel} , the results are

$$r_{\perp} v_{\perp} = \frac{k_B T}{F_{\perp} D^{\S}} v_{\perp}^2 \quad r_{\parallel} v_{\parallel} = \frac{k_B T}{F_{\parallel} D^{\S}} v_{\parallel}^2. \quad (27)$$

These equations introduce the confinement forces F_{\perp} and F_{\parallel} that constrain the carrier path within the tunnel and correspond to the interaction of the charge carrier with the neighbours lattice cores surrounding the stretched zone of the dislocation. Also, as the eqs (21) yield $v_{\perp} = \pm v_{\parallel} \tan \varphi$, one finds

$$T \leq \frac{m v_{\parallel}^2}{2k_B} \left(\frac{\delta l}{L} - \frac{k_B T v_{\parallel}}{F_{\perp} D^{\S}} \tan^2 \varphi \right)^2$$

which is more conveniently rewritten as follows

$$\frac{T}{T_c} \leq \frac{m v_{\parallel}^2}{2k_B T_c} \left(\frac{\delta l}{L} - \frac{T}{T_c} \frac{v_{\parallel}}{v_c} w \left(\frac{\delta l}{L} \right)^2 \right)^2 \quad (28)$$

$$F_{\perp} D^{\S} = v_c k_B T_c \quad \tan \varphi = \pm w \frac{\delta l}{L} + \dots$$

The meaning of the second equation is at the moment merely formal, aimed to obtain an expression function of T/T_c and v_{\parallel}/v_c ; as concerns the third position, is attracting the idea of writing the expression in parenthesis as a power series expansion of $\delta l/L$ truncated at the second order, in which case the proportionality constant w defines the series coefficient $T v_{\parallel} w / (T_c v_c)$. Note that this coefficient should expectably be of the order of the unity, in order that the series could converge; indeed this conclusion will be verified in the next subsection 5.2. Clearly v_c is definable as the transit critical velocity of the charge carrier making equal to 1 the right hand side of the first eq (28). Anyway both positions are acceptable because neither of them needs special hypotheses, being mere formal ways to rewrite the initial eq (26). This equation emphasizes that even when $v_{\perp} = 0$, i.e. in the particular case where the entrance path of the charge carrier is exactly aligned along v_{\parallel} , the mere thermal agitation must be consistent itself with the available tunnel cross section: the greater the latter, the higher the critical temperature below which the tunnelling is in fact allowed to occur. This equation links the lattice features δl and L to the operating conditions of the cell, here represented by the ion properties m and v_{\parallel} . Hence it is reasonable to expect that v_T and thus T must not exceed a critical upper value in order to allow the tunnelling

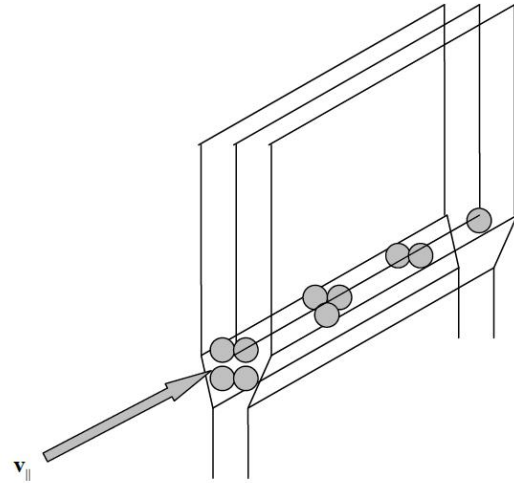

Fig. 7: The figure highlights that the arising of a concentration gradient along the tunnel is hindered by the size of the stretched zone of the dislocation.

mechanism. If T and m , and thus v_T , are such that $v_{\parallel} \delta t$ really corresponds to the whole length L of the dislocation, then the eqs (17) describe the flow of ions that effectively tunnel in the stretched zone of the dislocation.

4.3 The superconducting charge flow

The main feature of these results is that D^{\S} and ∇n characterize the charge tunnelling path. In general the occurring of concentration gradient requires by definition a volume of electrolyte so large to allow the non-equilibrium distribution of a statistically significant number of charge carriers unevenly distributed among the respective lattice sites. Yet $\nabla n \neq 0$ is in fact inconsistent with the size of the dislocation stretched zone here concerned; in particular, the existence of the component $\mathbf{u}_{\parallel} \cdot \nabla n$ of this gradient would require a configuration of charges like that qualitatively sketched in fig. 7.

This chance seems however rather improbable because of the mutual repulsion between charges of the same sign in the small channel available below the dislocation extra plane. So the gradient term at right hand side of the eq (22) should intuitively vanish inside the tunnel. Assume thus the component $\mathbf{u}_{\parallel} \cdot \nabla n = 0$, i.e. the carriers travel the stretched zone with null gradient within the tunnel path. To better understand this point, note that in the eq (22) appears the product $D^{\S} \nabla n$; moreover, in the eqs (27) appear the products $F_{\perp} D^{\S}$ and $F_{\parallel} D^{\S}$. These results in turn suggest two chances allowed at left hand side of eq (22):

(i) $v_{\parallel} = 0$, i.e. all charges are statistically at rest in the stretched zone; the eq (22) trivially consisting of null terms at both sides is nothing else but the particular case of the Cottrell

atmosphere sketched in fig. 3A. The ions that decorate the dislocation prevent the tunnelling of further ions provided by the lattice. The charge flow in the cell is merely that described by the usual bulk lattice ion transport under concentration and electric potential gradients, already concerned in [9].

(ii) The left hand side of the eq (22) is non-vanishing: $v_{\parallel} \neq 0$ reveals actual dynamics of charges transiting within the tunnel zone. This is closely related to the previous statement of the section 1 according which, for instance, a bare electron of mass m_e interacting with the dislocation can be described by a free electron of effective mass m_e^{eff} : owing to the eqs (2), this reasoning is identically expressed in general via D^{eff} instead of m^{eff} of any charge carrier.

The latter case is interesting, because the finite value of $v_{\parallel} \neq 0$ requires that $D^{\S} \rightarrow \infty$ in order that the undetermined form $\infty \times 0$ makes finite the corresponding limit value of $D^{\S} \mathbf{u} \cdot \nabla n$. This also means that $D^{\text{eff}} = D^* + D^{\S}$ tends to infinity as well, which compels the resistivity $\rho^{\text{eff}} \rightarrow 0$ according to eq (4). Moreover, for the same reason this mechanisms implies both $F_{\perp} \rightarrow 0$ and $F_{\parallel} \rightarrow 0$ for $D^{\S} \rightarrow \infty$, which implies $D_{\perp}^{\S} \rightarrow \infty$ and $D_{\parallel}^{\S} \rightarrow \infty$; this in turn means null interaction of the charge carrier with the lattice surrounding the tunnel zone. Hence the eqs (28) and (27) yield

$$\frac{T}{T_c} = \frac{mv_{\parallel}^2}{2k_B T_c} \left(\frac{\delta l}{L} - \frac{T}{T_c} \frac{v_{\parallel}}{v_c} w \left(\frac{\delta l}{L} \right)^2 \right)^2 \quad (29)$$

$$\lim_{\substack{D^{\S} \rightarrow \infty \\ F_{\perp} \rightarrow 0}} \frac{F_{\perp} D^{\S}}{k_B} = v_c T_c \quad \lim_{\substack{D^{\S} \rightarrow \infty \\ F_{\parallel} \rightarrow 0}} \frac{F_{\parallel} D^{\S}}{k_B} = v'_c T_c.$$

In the eqs (28) T_c and v_c were in general arbitrary variables; here instead they are fixed values uniquely defined by the limit of the second and third equations; the same holds for v'_c related to v_{\parallel} . So the transport mechanism in the stretched boundary zone of the dislocation extra plane is different from that in other zones of the ceramic crystal: clearly the former has nothing to do with the usual charge displacement throughout the lattice concerned by the latter. While the concentration gradient is no longer the driving force governing the charge transport, $F_{\perp} \rightarrow 0$ and $F_{\parallel} \rightarrow 0$ consequently obtained mean that the charge carrier moves within the tunnel as a free particle: the lack of friction force, i.e. electrical resistance, prevents dissipating their initial access energy into the dislocation stretched zone. This appears even more evident in the eq (5), where $D \equiv D^{\S}$ at $T = T_c$ yields $\mathbf{J} \neq 0$ compatible with $\mathbf{F} = 0$.

Simple considerations with the help of fig. 8, inferred from the fig. 4 but containing the information $\rho^{\text{eff}} \rightarrow 0$, show the electric shunt between zones of different electrical resistivity and highlight why the charge carriers tend to privilege the zero resistance tunnel path: this answers the possible question about the preferential character of this conduction mechanism of the charge carriers. Further quantum considerations are necessary to complete the picture essentially clas-

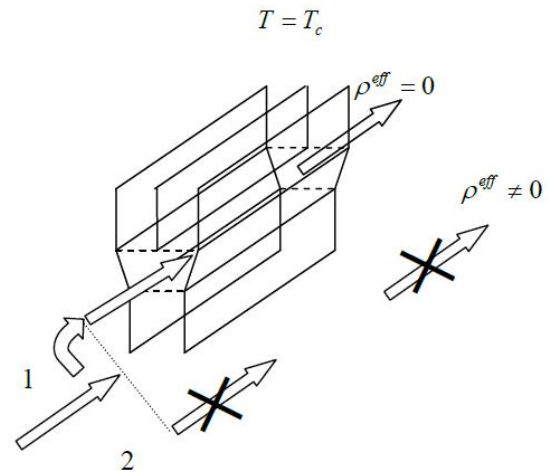

Fig. 8: Schematic sketch showing that at the ion current shunts to the zero resistivity path inside the tunnel with electrical resistivity $\rho^{\text{eff}} = 0$ rather than to any lattice path with $\rho^{\text{eff}} \neq 0$.

sical so far carried out. On the one hand the expectation of a superconducting flow of charges cannot be certainly regarded as an unphysical result, despite its derivation has surprisingly the classical basis hitherto exposed. In this respect however it is worth recalling the quantum nature of both eqs (1), which indeed have been obtained as corollaries of the statistical formulation of the quantum uncertainty [10]; the fact that the Fick equations have been obtained themselves as corollaries of a quantum approach to the gradient driven diffusion force, shows that actually all results have inherently quantum physical meaning. Then, by definition, even a classical approach inferred from these equations has intrinsic quantum foundation. On the other hand, the heuristic character of this section requires being completed with further concepts more specifically belonging to the quantum world.

5 Quantum approach

This section aims to understand why the results of the classical model of a unique dislocation crossing through one single grain are actually extendible to a real grain with several disconnected dislocations of different orientations and to the grain boundaries consisting of several tangled dislocations inordinately piled up at the interface with other grains.

5.1 Grain bulk superconductivity

Define $\delta\varepsilon = \varepsilon_{tu} - \varepsilon_{la}$, being ε_{tu} the energy of the ion travelling the tunnel along the stretched zone of the edge dislocation and ε_{la} that of the ions randomly moving in the lattice before entering the tunnel; $\delta\varepsilon$ represents thus the gap between the energy of the ion in either location, which in turn suggests

the existence of an energy gap for a charge carrier in the superconducting and non-superconducting state. This conclusion is confirmed below. The fact of having introduced the tunnelling velocity components \mathbf{v}_\perp and \mathbf{v}_\parallel , suggests introducing the respective components of De Broglie momentum of the ion corresponding to ε_{tu} . Being $p_\parallel = h/\lambda_\parallel$ and $p_\perp = h/\lambda_\perp$ these components, then $|\mathbf{p}| = h\sqrt{\lambda_\perp^{-2} + \lambda_\parallel^{-2}}$ in the tunnel state; λ_\perp and λ_\parallel are the wavelengths corresponding to the respective velocity components. Let us specify $n_\perp\lambda_\perp = \delta l$ and $n_\parallel\lambda_\parallel = L$, in order to describe steady waves with n_\perp and n_\parallel nodes along both tunnel sizes; then, with $n_\perp = 1$ and $n_\parallel = 1$,

$$p_{tu} = |\mathbf{p}| = \gamma h/\delta l \quad \gamma = \sqrt{1 + (\delta l/L)^2}.$$

Note that $\gamma \approx 1$ approximates well p_{tu} even if L corresponds to just a few lattice sites aligned to form the extra-plane of the edge dislocation, i.e. even in the case of an extra-plane extent short with respect to the lattice spacing stretched to δl : indeed $(\gamma h/\delta l - h/\delta l)/(\gamma h/\delta l) \approx (\delta l/L)^2/2$ yields $\gamma \approx 1$ even for values $L \gtrsim \delta l$. Anyway with $p_{tu} = \gamma h/\delta l$ one finds $\varepsilon_{tu} = (h\gamma)^2/2m\delta l^2$. According to this result, the momentum is essentially due to the small cross section of the stretched zone that constrains the transverse velocity component \mathbf{v}_\perp of the ion in the tunnel with respect to that of the ion randomly moving in the lattice; this means that remains instead approximately unchanged the component \mathbf{v}_\parallel of velocity along the tunnel. Put now $\varepsilon_{la} = \vartheta\varepsilon_{tu}$, being ϑ an appropriate numerical coefficient such that $\delta\varepsilon = (\vartheta - 1)\varepsilon_{tu}$. In principle both chances $\vartheta \gtrsim 1$ are possible, depending on whether $\varepsilon_{la} \gtrsim \varepsilon_{tu}$: as neither chance can be excluded "a priori" for an ion in the two different environments, this means admitting that in general to the unique ε_{la} in the lattice correspond two energy levels spaced $\pm\delta\varepsilon$ around ε_{tu} , one of which is actually empty depending on either situation energetically more favourable. This is easily shown as the eqs (24) yield two chances for the energy of the charge carrier in the tunnel, depending on how \mathbf{v}_T combines with \mathbf{v}_\parallel and \mathbf{v}_\perp . These equations yield $\varepsilon_2 = ((r_\parallel\mathbf{v} + \mathbf{v}_T)^2 + (r_\perp\mathbf{v} - \mathbf{v}_T)^2)m/2$ and $\varepsilon_1 = ((r_\parallel\mathbf{v} - \mathbf{v}_T)^2 + (r_\perp\mathbf{v} + \mathbf{v}_T)^2)m/2$; trivial manipulations via the eqs (21) yield thus $\delta\varepsilon = \varepsilon_2 - \varepsilon_1 = 2m\mathbf{v} \cdot \mathbf{v}_T(r_\parallel - r_\perp)$ showing indeed a gap between the levels $\varepsilon_2 = \varepsilon_0 + m\mathbf{v} \cdot \mathbf{v}_T(r_\parallel - r_\perp)$ and $\varepsilon_1 = \varepsilon_0 - m\mathbf{v} \cdot \mathbf{v}_T(r_\parallel - r_\perp)$ with $\varepsilon_0 = ((r_\parallel^2 + r_\perp^2)v^2/2 + v_T^2)m$: this latter corresponds thus to the Fermi level between the occupied and unoccupied superconducting levels defining the gap. As the ion dwell time δt in the tunnel is of the order of

$$\delta t = \frac{\hbar}{|\delta\varepsilon|} = 2\frac{m\delta l^2\hbar}{|\vartheta - 1|(\gamma h)^2},$$

the extent L of the extra-plane controlling the time range of ion transit at velocity v_\parallel requires

$$L = v_\parallel\delta t = \frac{mv_\parallel\delta l^2}{|\vartheta - 1|\pi h\gamma^2}.$$

So, supposing that n_{tu} electrons ξ apart each other transit simultaneously within the tunnel,

$$L = \frac{v_\parallel\hbar}{|\delta\varepsilon|} = \frac{v_\parallel\hbar}{|\vartheta - 1|\varepsilon_{tu}} \quad L = (n_{tu} - 1)\xi \quad v_\parallel = \frac{\gamma h}{m\delta l}$$

suggest that

$$\xi = \frac{v_\parallel\hbar}{(n_{tu} - 1)|\delta\varepsilon|} = \frac{v_\parallel\hbar}{|\vartheta - 1|(n_{tu} - 1)\varepsilon_{tu}}.$$

Define now the tunnel volume V available to the transit of the ions as $V = \chi L\delta l^2$, being χ a proportionality constant of the order of the unity related to the actual shape of the stretched zone; if for instance the tunnel would be simulated by a cylinder of radius $\delta l/2$, then $\chi = \pi/4$. Hence

$$V = \chi\delta l^2 v_\parallel\delta t = \frac{\chi}{|\vartheta - 1|\pi} \frac{m v_\parallel\delta l}{h} \delta l^3.$$

Note that $v_\parallel\delta l$ has the same physical dimensions of a diffusion coefficient; so it is possible to write $v_\parallel\delta l = \psi D_\parallel$, being ψ an appropriate proportionality constant. Moreover recall that the diffusion coefficient has been also related in the section 1 to h/m via a proportionality constant, once more because of dimensional reasons; so put $D_m = q_m h/m$ via the proportionality factor q_m , as done in the section 1, whereas the subscript emphasizes that the diffusion coefficient is by definition that related to the mass of an ion or electron tunnelling in the stretched zone of the dislocation. So one finds

$$V = \frac{\chi\psi}{|\vartheta - 1|\pi\gamma^2} \frac{D_\parallel}{q_m D_m} \delta l^3.$$

Note eventually that it is certainly possible to write $V/\delta l^3 = \theta(1 + \zeta)$ with $\zeta > 1$ appropriate function and θ proportionality constant: indeed the tunnel can be envisaged as a series of cells of elementary volumes $L_0\delta l^2$, where L_0 corresponds to the lattice spacing of atoms aligned along the dislocation extra plane. Replacing these positions in the equation of V one finds

$$\frac{D_\parallel}{q D_m} = 1 + \zeta \quad q = \frac{|\vartheta - 1|\theta\pi q_m}{\chi\psi} \gamma^2.$$

This result compares well with the eq (2) previously obtained in an independent way, simply identifying $\zeta = \partial^2 u(k)/\partial k^2$ and all constants with q ; as expected here D_\parallel plays at $T = T_c$ the role of D^* introduced in the section 1, whereas $q D_m$ is just D^* previously obtained as electric potential driven enhancement of the plain diffusion coefficient $D \equiv D_m$. This agreement supports the present approach. This also suggests some more considerations about the nature of the superconducting charge wave propagating along the tunnel zone. It is intuitive that the quantum states of the charge carriers within the tunnel must correspond to an ordered flow of particles, all travelling the tunnel with the same velocity v_\parallel ; any perturbation of the motion of these charges would increase the total

Coulomb energy of the flow and could even spoil the flow; the low temperature helps in this respect. This requires in turn a sort of coupling between the carriers, because several fermions cannot have the same quantum state; in effect it is known that a small contraction of positive charges of the lattice cores around the transient electrons in fact couples two electrons. Actually, in this case the contraction is that of the lines of lattice cores delimiting the tunnel stretched by the dislocation plane around the transient charges. In other words, electron pairs or proton pairs travel through the tunnel as bosons with a unique quantum state.

5.2 Computer simulation

Some estimates are also possible considering a ceramic lattice whose average spacing is a ; this is therefore also the order of magnitude expected for the size $\delta l \gtrsim a$ of the stretched zone. Consider first the case where the charge carrier is an electron, which requires negatively charged ion cores delimiting the tunnel cross section; this assumption reminds the familiar case of electron super-conduction and thus helps to check reliability and rationality of the estimates. To assess the previous results, put $m = 9 \times 10^{-28}$ g and consider the reasonable simulation value $\delta l = 5 \times 10^{-8}$ cm, consistent with a typical lattice spacing quoted in the section 3; one finds $v_{\parallel} \approx 1.5 \times 10^8$ cm/s with the approximation $\gamma = 1$. Moreover putting $L = 10^{-4}$ cm, i.e. considering an edge dislocation that crosses through a test grain average size of the typical order of $1 \mu\text{m}$, one finds a gap $\delta\varepsilon = v_{\parallel}\hbar/L = 10^{-3}$ eV between the ion energies in the tunnel and in the lattice. Note that the zero point energy of a free ion in such a test lattice would be of the order of $\varepsilon_{la} \approx 3\hbar^2/2ma^2 \approx 0.3$ eV, quite small with respect to the definition value 1 eV of one electron or unit charge ion in a ceramic electrolyte of a cell operating with 1 V. To ε_{la} corresponds the zero point vibrational frequency $\nu = 2\varepsilon_{la}/h$, i.e. $\nu \approx 2 \times 10^{14}$ s $^{-1}$; with such a frequency the wavelength $\lambda_{\parallel} = L$ corresponds to a total charge wave due to $L\nu/v_{\parallel}$ electrons. So one finds $\approx 10^2$ electrons, whose mean mutual distance is thus 10 nm about. Eventually the critical temperature compatible with the arising of the superconducting state given by the eq (26) is 0.02 K with $v_{\perp} = 0$ or even smaller for $v_{\perp} \neq 0$. Compare now this result obtained via the eq (26) with that obtainable directly through the eq (25)

$$v_T^2 = \left(\frac{r_{\perp}^2}{\cos^2\varphi} + (1 - 2r_{\perp})\tan^2\varphi \right) v_{\parallel}^2.$$

Note that v_T^2 has a minimum as a function of r_{\perp} . If $\varphi = \pi/2$ this minimum corresponds to $r_{\perp}^{\min} = 1$, to be rejected because it would imply $D_{\perp}^{\S} = D^{\S}$ and $D_{\parallel}^{\S} = 0$. If instead $\varphi \neq \pi/2$, then the minimum corresponds to $r_{\perp}^{\min} = \sin^2\varphi$, which yields in turn $v_T^2 = v_{\parallel}^2 \sin^2\varphi$; hence $k_B T_c = mv_T^2/2$ yields

$$T_c = \frac{m}{2k_B} v_{\parallel}^2 \sin^2\varphi.$$

With $v_{\parallel} = 1.5 \times 10^8$ cm/s the electron mass would yield $T = 6.2 \times 10^6 \sin^2\varphi$ K. Comparing with the previous result, one infers that $10^{-8} \gtrsim \sin^2\varphi$; so being $\sin^2\varphi \approx \tan^2\varphi$ with good approximation, one also infers that the second position (28) is verified with w such that $T v_{\parallel} w / (T_c v_c)$ is of the order of unity for $\delta l/L = 10^{-4}$, as in fact it has been anticipated in the previous subsection 4.3. Of course the actual values of these order of magnitude estimates depend on the real microstructure of the ceramic lattice; yet the aim of this short digression concerning the electron is to emphasize that the typical properties of the test material used for this simulation are consistent with the known results of electron superconduction theory. The simulation can be repeated for the proton, considering that the proton velocity v_{\parallel} is now m_e/m_{prot} times lower than before; so, despite m is m_{prot}/m_e larger than before, mv_{\parallel}^2 of the eq (26) predicts a critical T smaller than that of the electron by a factor m_e/m_{prot} for $r_{\perp} v_{\perp} \ll v_{\parallel} \delta l/L$.

5.3 Grain bulk and grain boundary superconductivity

As concerns the chance of superconduction in the grain bulk with several disconnected dislocations at the grain boundaries, it is necessary to recall the Josephson effect concurrently with the presence of tangled dislocations and pile up of dislocations. The former concerns the transfer of superconducting Cooper pairs existing at the Fermi energy via quantum tunnelling through a thin thickness of insulating material: it is known that the tunnelling current of a quasi-electron occurs when the terminals of two dislocations, e.g. piled up or tangled, are so close to allow the Josephson Effect. If some terminals are a few nanometers apart, then superconduction current is still allowed to occur even though the dislocation break produces a thin layer of ceramic insulator. In other words, the terminal of the superconducting channel of one dislocation transfers the pair to the doorway of another dislocation and so on: in this way a superconduction current can tunnel across the whole grain. An analogous idea holds also at the grain boundary. Of course the chance that this event be actually allowed to occur has statistical basis: due to the high number of dislocations that migrate and accumulate at the grain boundaries after displacement along favourable slip planes of the bulk crystal lattice, the condition favourable to the Josephson Effect is effectively likely to occur. As the same holds also within the grain bulk between two different dislocations close enough each other, e.g. because they glide preferentially along equal slip planes and pile up on bulk precipitates, the conclusion is that the pair tunnelling allows macroscopic superconduction even without necessarily requiring the classical case of a unique dislocation spanning throughout a single crystal electrolyte.

6 Discussion

It is commonly taken for granted that the way of working of the fuel cells needs inevitably high temperatures, of the or-

der of some hundreds C degrees, so as to promote adequately the ion conductivity; great efforts are addressed to reduce as much as possible this temperature, down to a few hundreds C degrees, yet still preserving an acceptable efficiency of the cell compatibly with the standard mechanisms of ion conduction.

The present paper proposes however a new approach to the problem of the electric conduction in solid oxide electrolytes: reducing the operating temperature of SOFCs down to a few K degrees, in order to promote a superconducting mechanism.

Today the superconductivity is tacitly conceived as that of the electrons only; the present results suggest however that at sufficiently low temperatures, even the low atomic number ions are allowed to provide an interaction free conduction thanks to their chance of tunnelling in the stretched zone of edge dislocations. Note that although the electron and ion superconduction occur at different temperatures, as it is reasonable to expect, the nature of the lattice cores appears able to filter either kind of mechanism during the working conditions of the cell for the reasons previously remarked: for instance positively charged cores hinder the electron superconduction by attractive Coulomb effect, while promoting instead the proton superconduction via the repulsive effect that keeps the proton trajectory in the middle of the stretched channel. The results obtained in this paper support reasonably the chance that, at least in principle, this idea is practicable. Of course other problems, like for instance the catalysis at the electrodes, should be carefully investigated at the very low temperatures necessary to allow the ion superconduction. However this side problem, although crucial, has been deliberately waived in the present paper: both because of its different physicochemical nature and because the foremost aim of the model was (i) to assess the chance of exploiting the superconductivity not only for the electric energy transmission but also for the electric energy production and (ii) to bring this intriguing topic of the quantum physics deeply into the heart of the fuel cell science.

Moreover other typical topics like the penetration depth of the magnetic field and the critical current have been skipped because well known; the purpose of the paper was not that of elaborating a new theory of superconductivity, but to ascertain the feasibility of an ion transport mechanism able to bypass the difficulties of the high temperature conductivity. Two considerations deserve attention in this respect. The first one concerns the requirement $\mathbf{u}_{\parallel} \cdot \nabla n = 0$ characterizing the superconductive state with $D \rightarrow \infty$. At first sight one could naively think that the eq (4) should exclude a divergent diffusion coefficient. Yet the implications of a mathematical formula cannot be rejected without a good physical reason. Actually neither the chain of equations (6) nor the eq (19) exclude $D \rightarrow \infty$: the former because it is enough to put the lattice-charge interaction force $\mathbf{F} \rightarrow 0$ whatever \mathbf{v} and $k_B T$ might be, the latter provided putting concurrently $\nabla\phi = -\mathbf{E}e \rightarrow 0$. The prod-

uct $\infty \times 0$ is in principle not necessarily unphysical despite D diverges, because this divergence is always counterbalanced by some force or energy or concentration gradient concurrently tending to zero; rather it is a matter of experience to verify whether the finite outcomes of these products, see for instance the eqs (29), have experimental significance or not. In this respect, however, this worth is recognized since the times of Onnes (1913). In fact, the electron superconductivity is nothing else but a frictionless motion of charges, somehow similar to the superfluidity. Coherently, both equations (29) and (10) suggest simply a free charge carrier moving without need of concentration gradient or applied potential difference or electric field or force \mathbf{F} of any physical nature. The essence of the divergent diffusion coefficient is thus the lack of interaction between lattice and charge carrier. In this sense the Nernst-Einstein equation is fully compatible even with $D^{eff} \rightarrow \infty$: in fact is hidden in this limit, and thus in the eq (4) itself, the concept of superconductivity, regarded as a peculiar charge transport mechanism that lacks their interactions and thus does not need any activation energy or driving force.

These results disclose new horizons of research as concerns the solid oxides candidate for fuel cell electrolytes. The choice of the best oxides and their heat treatments is today conceived having in mind the best high temperature conductivity only. But besides this practical consideration, nothing hinders in principle exploring the chance of a fuel cell realized with MIEC solid oxides designed to optimize the ion superconducting mechanism. The prospective is that MIECS with poor ionic conductivity at some hundreds degrees could have excellent superconductors at low temperatures. It seems rational to expect that the optimization of the electrolytes for a next generation of fuel cells compels the future research not to lower as much as possible the high temperatures but to rise as much as possible the low temperatures.

7 Conclusion

The model has prospected the possibility of SOFCs working at very low temperatures, where superconduction effects are allowed to occur. Besides the attracting importance of the basic and technological research aimed to investigate and develop high temperature superconductors for the transport of electricity, the present results open new scenarios as they concern the production itself of electric power via zero resistivity electrolytes. Of course the chance of efficient fuel cells operating according to these expectations must be verified by the experimental activity; if the theoretical previsions are confirmed at least in the frame of a preliminary laboratory activity, as it is legitimate to guess since no ad hoc hypothesis has been introduced in the model, then the race towards high Tc electrolytes could allow new goals of scientific and applicative interest.

Submitted on December 9, 2014 / Accepted on December 12, 2014

References

1. Murch G.E. Atomic diffusion theory in highly defective solids. Trans Tech Publications, Limited, 1980
2. Kontturi K., Murtoimäki L., Manzanares J.A. Ionic Transport Processes in Electrochemistry and Membrane Science, 2008, Oxford University Press, Oxford, UK.
3. Gellings P.J., Bouwmeester H.J.M. (Eds.), CRC Handbook of Solid State Electrochemistry, CRC Press, 1997.
4. Riess I. Mixed ionic–electronic conductors - material properties and applications. *Solid State Ionics*, 157, (2003).
5. Eoin M. NMR studies of conduction mechanisms in electrolyte materials for fuel cells. PhD Thesis, University of Dublin, School of chemical Sciences, 2007.
6. Hong G.W., Lee J.Y. The interaction of hydrogen with dislocations in iron. *Acta Metallurgica*, 1984, v.32(10), p. 1581.
7. Rice M.J., Roth W.L. Ionic transport in super ionic conductors: a theoretical model. *Journal of Solid State Chemistry*, 1972, v. 4(2), p. 294.
8. Boris B., Bokshtein S., Zhukhovitskii A. Thermodynamics and kinetics of diffusion in solids, 1985, Oxonian Press, NY.
9. Tosto S. Correlation model of mixed ionic-electronic conductivity in solid oxide lattices in the presence of point and line defects for solid oxides fuel cells *International Journal of Energy Research*, 2011, v. 35(12), p. 1056.
10. Tosto S. Fundamentals of diffusion for optimized applications, 2012, ENEA Ambiente Innovazione, p. 94.
11. Freemann S.A., Booske J.H., Cooper R.F., Modeling and numerical simulations of microwave induced ion transport. *Journal of Applied Physics*, 1998, v. 83(11), 2979.
12. Karger J., Heitjans P., Haberlandt R. Diffusion in Condensed Matter, 1998, Friedr. Vieweg and Sohn Verlagsgesell. mbH Braunschweig.
13. Kittel C. Introduction to solid state physics, 2005, J. Wiley and Sons, Hoboken, NJ, USA.
14. Sutton A.P. and Balluffi R.W. Interfaces in Crystalline Materials. 1995 Clarendon Press, Oxford, UK.
15. Zhao J.Z., De A.K., De Cooman B.C. Formation of the Cottrell Atmosphere during Strain Ageing of Bake-Hardenable Steels, *Metallurgical and Materials Transactions*, 2001, v. 32A, p. 417.
16. Conrad H., Schoeck G. Cottrell locking and the flow stress in iron. *Acta Metallurgica*, 1960, v. 8(11), 791–796.
17. Slater J.C. Atomic Radii in Crystals. *Journal of Chemical Physics*, 1964, v. 41(10), 3199–3205.
18. Lande A. *Zeitschrift für Physik*, 1920, v. 1(3), p. 191.
19. Otake H. and Nakamura A. Lattice Parameters and Defect Structure of the Fluorite and C-Type Oxide Solid Solutions between MO₂ and M₂O₃, in Solid Oxide Fuel Cells (SOFCs VI): Proc. Of the Sixth International Congress, S.C. Singhal and M. Dokiya Eds, 1999, p. 463, The Electrochemical Society, Pennington, N.J., USA.